

Regular and irregular semiclassical wavefunctions

M V Berry

H H Wills Physics Laboratory, Bristol University, Tyndall Avenue, Bristol BS8 1TL, UK

Received 19 July 1977, in final form 11 August 1977

Abstract. The form of the wavefunction ψ for a semiclassical regular quantum state (associated with classical motion on an N -dimensional torus in the $2N$ -dimensional phase space) is very different from the form of ψ for an irregular state (associated with stochastic classical motion on all or part of the $(2N - 1)$ -dimensional energy surface in phase space). For regular states the local average probability density Π rises to large values on caustics at the boundaries of the classically allowed region in coordinate space, and ψ exhibits strong anisotropic interference oscillations. For irregular states Π falls to zero (or in two dimensions stays constant) on 'anticaustics' at the boundary of the classically allowed region, and ψ appears to be a Gaussian random function exhibiting more moderate interference oscillations which for ergodic classical motion are statistically isotropic with the autocorrelation of ψ given by a Bessel function.

1. Introduction

In generic classical Hamiltonian bound systems with $N (\geq 2)$ degrees of freedom some orbits wind smoothly round N -dimensional tori in the $2N$ -dimensional phase space, and some orbits explore $(2N - 1)$ -dimensional regions of the energy 'surface' in a stochastic manner (Arnol'd and Avez 1968, Ford 1975, Whiteman 1977, Berry 1978). Percival (1973) took up an old idea of Einstein (1917) and suggested that in the semiclassical limit (i.e. as $\hbar \rightarrow 0$) there would be 'regular' and 'irregular' quantum states corresponding to these two sorts of classical motion. In the limiting case of a completely integrable system the whole phase space is filled with tori and all states are regular, and in the opposite limit of a completely ergodic system almost all orbits wander stochastically over the whole energy surface and all states are irregular. According to Percival regular and irregular states could be distinguished by their behaviour under perturbation; this distinction obviously involves the matrix elements between *different* states.

Here I make conjectures about *individual* energy eigenstates. It appears that the nature of the wavefunction $\psi(\mathbf{q})$ is very different as $\hbar \rightarrow 0$ for regular and irregular states. The main differences are in the behaviour near boundaries of classically allowed regions (§ 2) and in the nature of the oscillations of $\psi(\mathbf{q})$ (§ 3). These differences suggest simple ways in which a quantum state numerically computed or graphically displayed can be shown to be regular or irregular.

The quantities to be calculated are *local averages* over coordinates $\mathbf{q} (\equiv q_1 \dots q_N)$ of functions $f(\mathbf{q})$ that depend on $\psi(\mathbf{q})$, denoted by $\bar{f}(\mathbf{q})$ and defined by

$$\bar{f}(q_1 \dots q_N) \equiv \frac{1}{\Delta^N} \int_{q_1 - \frac{1}{2}\Delta}^{q_1 + \frac{1}{2}\Delta} dQ_1 \dots \int_{q_N - \frac{1}{2}\Delta}^{q_N + \frac{1}{2}\Delta} dQ_N f(Q_1 \dots Q_N), \quad (1)$$

where

$$\lim_{\hbar \rightarrow 0} \Delta = 0 \quad \text{but} \quad \lim_{\hbar \rightarrow 0} (\hbar/\Delta) = 0. \tag{2}$$

The conditions on Δ ensure that the average \bar{f} is taken over many oscillations of the wavefunction, since the scale of these oscillations is of order \hbar . I shall study the local average probability density $\Pi(\mathbf{q})$, namely

$$\Pi(\mathbf{q}) \equiv |\psi(\mathbf{q})|^2, \tag{3}$$

and the autocorrelation function $C(\mathbf{X}; \mathbf{q})$ of $\psi(\mathbf{q})$, namely

$$C(\mathbf{X}; \mathbf{q}) \equiv \overline{\psi(\mathbf{q} + \frac{1}{2}\mathbf{X})\psi^*(\mathbf{q} - \frac{1}{2}\mathbf{X})} / \Pi(\mathbf{q}). \tag{4}$$

The principal tool for this study is Wigner's function $\Psi(\mathbf{q}, \mathbf{p})$ corresponding to the state $\psi(\mathbf{q})$. This is defined as

$$\Psi(\mathbf{q}, \mathbf{p}) \equiv \frac{1}{h^N} \int d\mathbf{X} e^{-i\mathbf{p} \cdot \mathbf{X}/\hbar} \psi(\mathbf{q} - \frac{1}{2}\mathbf{X})\psi^*(\mathbf{q} + \frac{1}{2}\mathbf{X}). \tag{5}$$

Detailed studies of the semiclassical behaviour of Ψ have been made by Berry (1977a) and Voros (1976, 1977). In terms of Ψ , the local average probability density is

$$\Pi(\mathbf{q}) = \int d\mathbf{p} \Psi(\mathbf{q}, \mathbf{p}) \tag{6}$$

and the autocorrelation function is

$$C(\mathbf{X}; \mathbf{q}) = \int d\mathbf{p} e^{i\mathbf{p} \cdot \mathbf{X}/\hbar} \bar{\Psi}(\mathbf{q}, \mathbf{p}) / \Pi(\mathbf{q}). \tag{7}$$

For the present purposes it is sufficient to take for the averaged Wigner function $\bar{\Psi}$ the crudest classical approximation, namely the density in the classical phase space \mathbf{q}, \mathbf{p} over the manifold explored by the classical orbit corresponding to the quantum state ψ being considered. For an *integrable* system this is a torus, specified by the actions $\mathbf{I}_\psi = (I_1 \dots I_N)$ round the N irreducible cycles. Quantum conditions (reviewed by Percival 1977) select the \mathbf{I}_ψ that can correspond to quantum states. Any point (\mathbf{q}, \mathbf{p}) in phase space can be specified by the actions $\mathbf{I}(\mathbf{q}, \mathbf{p})$ of the torus through (\mathbf{q}, \mathbf{p}) and the conjugate angle variables $\boldsymbol{\theta}(\mathbf{q}, \mathbf{p})$ locating the position of (\mathbf{q}, \mathbf{p}) on this torus. Then the averaged Wigner function is (Berry 1977a):

$$\bar{\Psi}(\mathbf{q}, \mathbf{p}) = \frac{\delta(\mathbf{I}(\mathbf{q}, \mathbf{p}) - \mathbf{I}_\psi)}{(2\pi)^N}. \tag{8}$$

(Note that this involves an N -dimensional delta function.)

For an *ergodic* system I assume that the relevant classical orbits are the typical ones, that pass close to all points on the energy surface corresponding to the energy E of the state ψ . Then if $H(\mathbf{q}, \mathbf{p})$ denotes the classical Hamiltonian it is shown under reasonable assumptions by Voros (1976, 1977) that the averaged Wigner function is

$$\bar{\Psi}(\mathbf{q}, \mathbf{p}) = \frac{\delta(E - H(\mathbf{q}, \mathbf{p}))}{\int d\mathbf{q} \int d\mathbf{p} \delta(E - H(\mathbf{q}, \mathbf{p}))}. \tag{9}$$

(Note that this involves only a one-dimensional delta function.) The 'microcanonical' assumption (9) differs radically from that made by Gutzwiller (1971), who considers

that the relevant orbits in this case are the individual unstable periodic trajectories. Although dense, these are of total measure zero and this makes it unlikely that they could support quantum states (any attempt to use orbits in the neighbourhood of the periodic trajectories will be frustrated by their instability).

For a *quasi-integrable* system the existence of some tori is guaranteed by the 'KAM' theorem of Kolmogoroff (1954), Arnol'd (1963) and Moser (1962). Although these tori are distributed pathologically in phase space there are infinitely many of them near one with actions I_ψ and this, taken together with a smoothing on scales small in comparison with \hbar , is probably sufficient to give meaning to the function $I(q, p)$ and hence to (8). There will be gaps in the system of tori; in these gaps motion is stochastic and fills a $(2N - 1)$ -dimensional region smaller than the whole energy surface. Usually the orbits do not fill such stochastic regions uniformly but for simplicity I shall assume that they do. Then the averaged Wigner function will be given by (9) restricted to the region explored by the motion.

The Hamiltonian will be taken as

$$H(q, p) = \frac{p^2}{2m} + V(q) \tag{10}$$

where m is the mass of the system and $V(q)$ the potential in which it moves. This ensures that $\psi(q)$ can be considered real. The presence of a magnetic field or of anisotropy in the momentum terms introduces complications but no essential differences in the results.

2. Caustics and anticaustics

According to (6) the averaged probability density is the projection of the averaged Wigner function 'down' the p directions. The singularities of this projection are interesting because they show how $\Pi(q)$ behaves near the boundary of the classically allowed region in q space.

For integrable systems the projections of tori are singular on the well known *caustics* where $\Pi(q)$ becomes infinite. Explicitly, (6) and (8) give

$$\Pi(q) = \frac{1}{(2\pi)^N} \sum_i |dI(q, p_i(q))/d p|^{-1} = \frac{1}{(2\pi)^N} \sum_i |d\theta(q, p_i(q))/d q|, \tag{11}$$

where the derivatives denote Jacobian determinants and $p_i(q)$ is the i th intersection of a fibre through q with the torus I_ψ (there is always a finite number of these intersections). As q moves onto a caustic $|d\theta/dq|$ diverges as two or more intersections i coincide (figure 1).

It is the presence of caustics that gives regular wavefunctions their striking and distinctive properties. The forms of the caustics in generic cases are governed by the catastrophe theory of Thom (1972) and Arnol'd (1975). This is because for the part of the torus for which q lies near the caustic it is possible to define a local generating function $G(p; q)$ by

$$G(p; q) \equiv \int_{p_0}^p q(p') \cdot dp' - p \cdot q, \tag{12}$$

where $q = q(p)$ is the equation of the torus near its 'edge' (figure 1). In terms of G the

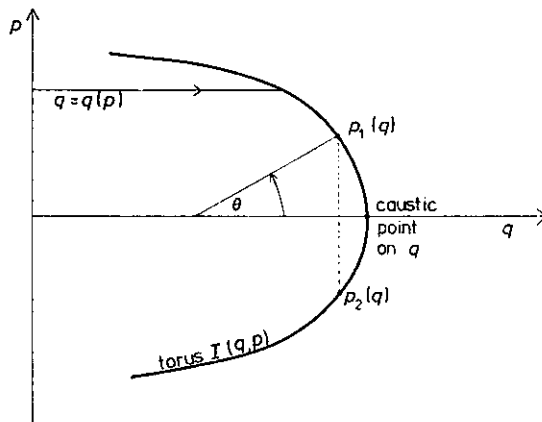

Figure 1. Coordinates and momenta near 'edge' of a torus in phase space.

gradient map

$$\nabla_p G = q(\mathbf{p}) - \mathbf{q} = 0 \tag{13}$$

defines the torus locally and the singularities of the map, where

$$|\det \partial^2 G / \partial p_i \partial p_j| = |dq/dp| = 0, \tag{14}$$

define the caustics in \mathbf{q} space. This follows from the second term of (11) on realising that \mathbf{p} varies smoothly with θ when \mathbf{q} is near a caustic (figure 1). (It is not possible to define a *global* generating function of the form (12), because (12) fails near caustics in momentum space where $q(\mathbf{p})$ is not defined.)

When $N = 2$ the possible catastrophes are fold lines and cusp points. If $V(\mathbf{q})$ is a simple potential well with circular symmetry, for example, there are no cusps and the caustic is two circular fold lines with radii determined by the libration points of the orbit. To see how such caustics are produced by projection it is simplest to visualise the tori in the three-dimensional energy surface \mathcal{E} with coordinates q_1, q_2 and the angle ϕ made by \mathbf{p} with the p_1 axis; because of the periodicity in ϕ the energy surface has the topology of a solid torus. Figure 2 shows \mathcal{E} and also a two-dimensional torus corresponding to motion with constant angular momentum.

Other forms of potential well can give rise to caustics with cusps, as illustrated by figure 3(e) which shows the caustic of an orbit computed by Marcus (private communication). One way this might arise can be introduced by first considering an isolated stable triangle orbit (figure 3(a)) on a non-circular billiard table (i.e. a potential zero for q_1, q_2 inside a boundary and infinite outside). This will be surrounded by tori in q_1, q_2, ϕ (Lazutkin 1973, Dvorin and Lazutkin 1973), one of which is shown in figure 3(b). The projection (caustic) is shown in figure 3(c); there are no cusps, and the non-generic triple junctions result from the discontinuity in $V(\mathbf{q})$ at the boundary. The 'generification' of the torus (figure 3(d)) that results from softening $V(\mathbf{q})$ at the boundary corresponds to pumping air into a flat tyre and on projection gives the cusped caustic of figure 3(e).

For $N > 2$ the caustics can typically form higher catastrophes. In each case $\Pi(\mathbf{q})$ rises to infinity at the caustic. For the fold, if x is normal distance from the caustic into

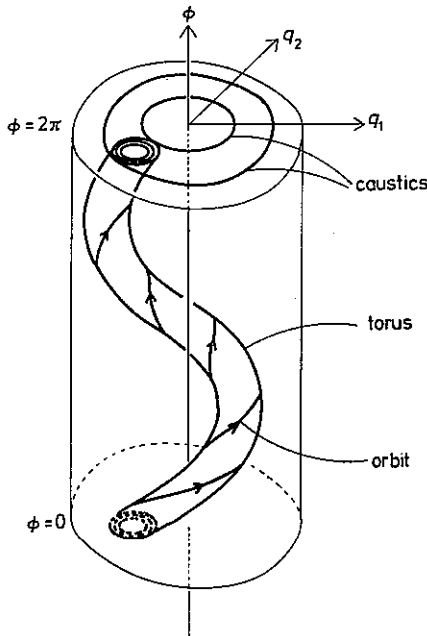

Figure 2. Energy 'surface' \mathcal{S} with coordinates (q_1, q_2, ϕ) ($\phi = 0$ and $\phi = 2\pi$ are identified). The torus corresponding to an orbit with constant angular momentum is shown, and the caustics which envelop its projection along ϕ .

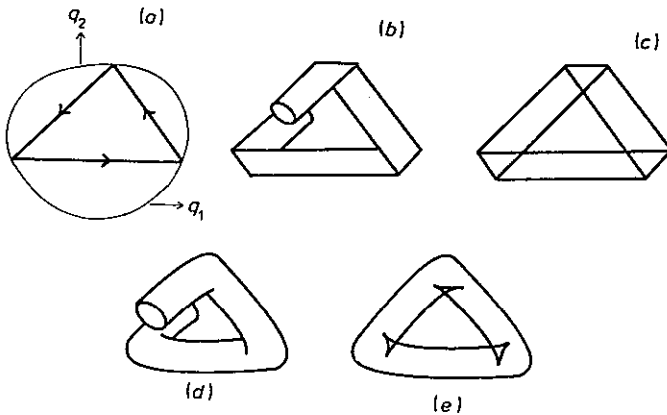

Figure 3. (a) Stable isolated closed orbit on billiard table; (b) torus in q_1, q_2, ϕ space (ϕ perpendicular to paper) inhabited by nearby quasi-periodic orbit; (c) caustic resulting from projection of (b); (d) generification of torus in (b) resulting from softening potential at the boundary; (e) caustic resulting from projection of (d).

the classically allowed region, the divergence has the form

$$\Pi \propto \text{Re } x^{-1/2}. \tag{15}$$

At higher catastrophes the divergence is stronger.

For non-zero \hbar the divergences are softened by quantum effects and ψ rises to a value of order $\hbar^{-\beta}$ where β is the 'singularity index' defined by Arnol'd (1975). The

caustics are clothed by striking diffraction patterns (Berry 1976) characteristic of the particular catastrophe involved.

This behaviour is very different from what happens in an ergodic system. There, equations (8), (9) and (10) give

$$\Pi(q) = \frac{\int dp \delta(E - H(q, p))}{\int dp \int dq \delta(E - H(q, p))} = \frac{(E - V(q))^{\frac{1}{2}N-1} \Theta(E - V(q))}{\int dq (E - V(q))^{\frac{1}{2}N-1} \Theta(E - V(q))} \quad (16)$$

where Θ denotes the unit step function. When $N > 2$, $\Pi(q)$ vanishes at the boundary $E = V(q)$ of the classically allowed region. For $N = 2$, $\Pi(q)$ is constant over the allowed region. In no case does Π diverge on the boundary (except in the trivial situation $N = 1$ when the system is integrable and ergodic and the boundary points are caustics of fold type). Therefore I shall call the boundaries of these irregular wavefunctions *anticaustics*.

In a quasi-integrable system the boundaries of the projections of stochastic regions corresponding to irregular states will also have anticaustics. As an example of this let $N = 2$ and consider a potential well perturbed from circularity. Surrounding each 'unperturbed' torus that supported closed orbits there will be a gap between the tori of the perturbed system. Let one such gap span the angular momenta L_1 to $L_2 (> L_1)$ and assume that the stochastic trajectories fill this gap uniformly. Then $\Pi(q)$ for a corresponding irregular quantum state will vary with radial coordinate q as

$$\begin{aligned} \Pi(q) &\propto \int_0^{2\pi} d\phi \int_0^\infty dp p \delta\left(E - V(q) - \frac{p^2}{2m}\right) \Theta(L_2 - pq \sin \phi) \Theta(pq \sin \phi - L_1) \\ &\propto \int_0^{2\pi} d\phi \Theta(L_2 - q[2m(E - V(q))]^{1/2} \sin \phi) \Theta(q[2m(E - V(q))]^{1/2} \sin \phi - L_1). \end{aligned} \quad (17)$$

If q_1^-, q_2^- are the inner libration radii for orbits with L_1 and L_2 , and q_1^+, q_2^+ are the corresponding outer libration radii, then

$$\Pi(q) \propto \begin{cases} 0 & (q < q_1^-, q > q_1^+) \\ \cos^{-1}\left(\frac{L_1}{q[2m(E - V(q))]^{1/2}}\right) & (q_1^- < q < q_2^-, q_2^+ < q < q_1^+) \\ \sin^{-1}\left(\frac{L_2}{q[2m(E - V(q))]^{1/2}}\right) - \sin^{-1}\left(\frac{L_1}{q[2m(E - V(q))]^{1/2}}\right) & (q_2^- < q < q_2^+) \end{cases} \quad (18)$$

The form of this expression is sketched in figure 4; it can be seen that there are indeed anticaustics at the outer boundaries of the classically allowed region, where $\Pi(q)$ rises as $(q - q_1^-)^{1/2}$ and falls as $(q_1^+ - q)^{1/2}$.

3. Autocorrelation of the wavefunction

The function $C(X; q)$ defined by (4) gives the scale and directionality of the pattern of oscillations of ψ near q . For an integrable system, (7) and (8) give (cf (11))

$$C(X; q) = \frac{\sum_i |d\theta(q, p_i(q))/dq| e^{ip_i(q) \cdot X/\hbar}}{\sum_i |d\theta(q, p_i(q))/dq|} \quad (19)$$

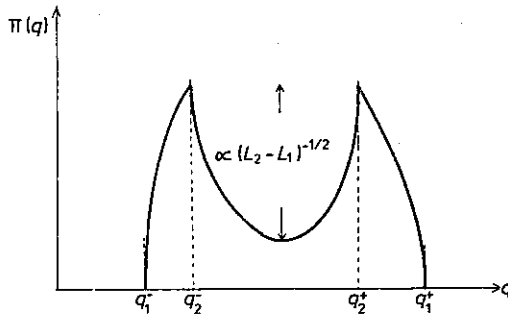

Figure 4. Local average probability density arising from projection of phase space region with constant energy between two tori corresponding to motions with angular momenta L_1 and L_2 .

The wavevectors p_i/\hbar in the ‘spectrum’ of ψ all have the same length $[2m(E - V(q))]^{1/2}/\hbar$ but different directions. There is a finite number of such wavevectors, so $C(\mathbf{X})$ is anisotropic. This anisotropy is most marked near a typical point on the caustic, where only two vectors (equal in magnitude and opposite in direction) contribute significantly to (19), giving rise to ‘Airy’ fringes parallel to the caustic.

Again this behaviour is very different from what happens in the ergodic case, where there are infinitely many contributing p vectors and the spectrum of ψ is continuous. When H is given by (10), equations (7) and (9) give

$$C(\mathbf{X}; q) = \frac{\int d\Omega \exp\{i\Omega \cdot \mathbf{X}[2m(E - V(q))]^{1/2}/\hbar\}}{\int d\Omega}, \tag{20}$$

where Ω is the unit vector along p . This integral can be evaluated in terms of standard Bessel functions to give

$$C(\mathbf{X}; q) = \Gamma(\frac{1}{2}N) \frac{J_{\frac{1}{2}N-1}(X[2m(E - V(q))]^{1/2}/\hbar)}{\{X[2m(E - V(q))]^{1/2}/2\hbar\}^{\frac{1}{2}N-1}}. \tag{21}$$

(For $N = 2$ and $N = 3$ this expression is simply $J_0(\xi)$ and $\sin \xi/\xi$ respectively, where ξ is the argument of the Bessel function.) Just as in the integrable case all oscillations of ψ have the de Broglie wavelength $\hbar/[2m(E - V(q))]^{1/2}$. Now, however, the oscillations near q are statistically isotropic, even close to the anticaustics.

The autocorrelation function is not by itself sufficient to determine all statistical properties of ψ . However it is likely that for stochastic classical motion the phases of the different contributions p to ψ are uncorrelated, because the orbit would accumulate many action units \hbar in its ‘unpredictable’ wanderings between passages through the neighbourhood of q . This would imply that ψ is a *Gaussian random function* of q (Rice 1944, 1945, Longuet-Higgins 1956), whose spectrum at q is simply the local average of the Wigner function $\bar{\Psi}(q, p)$. For ergodic motion $\bar{\Psi}$ is given by (9) leading to the isotropic statistics described by (21), while for non-ergodic stochastic motion in a gap between KAM tori the contributing p are continuously distributed over a limited range of directions resulting in ψ being a random wave whose statistics have some anisotropy. All statistical properties of a Gaussian random function (probability distribution of ψ and its derivatives, correlations between ψ at two or more points, etc) are determined by $\Pi(q)$ and $C(\mathbf{X}; q)$.

Of course ψ for an integrable system cannot be a Gaussian random function because its spectrum of wavevectors is discrete. However there exist in quasi-integrable systems stable closed orbits of arbitrarily complicated topology, which will be surrounded by tori whose projections onto q will be crossed by many caustics not confined to the boundary of the classically allowed region. It is meaningful to think of the wave ψ in the presence of such caustics as having statistical properties but these will be highly non-Gaussian as I have explained elsewhere (Berry 1977b).

4. Conclusions

I have suggested that in the semiclassical limit quantum energy eigenstates separate into two universality classes distinguished by the morphology of their wavefunctions. States in Percival's regular spectrum, associated with tori in classical phase space, have vivid patterns of regular interference fringes and violent fluctuations in intensity associated with caustics of the classical motion. In sharp contrast, states in Percival's irregular spectrum, associated with stochastic motion in phase space, have random patterns of interference maxima and minima (statistically isotropic in the ergodic case) with more temperate intensity fluctuations of Gaussian random type and 'anticaustics' at boundaries of the classical motion.

Closely analogous behaviour of wavefunctions is currently being studied in optics, in connection with Gaussian and non-Gaussian laser speckle patterns (Jakeman and Pusey 1975) and Gaussian and non-Gaussian twinkling of starlight (Jakeman *et al* 1976, Berry 1977b). Gaussian wavefunctions arise when waves traverse a medium producing an irregular wavefront whose topography varies rapidly on a wavelength scale, and non-Gaussian wavefunctions (with caustics, etc) arise when the wavefront varies smoothly on a wavelength scale. In both the optical and the quantum cases the different behaviour of ψ arises from the same cause: regular waves have underlying trajectories in phase space that are smoothly distributed on the scale of wavelength or \hbar , while in irregular waves the trajectories show structure down to scales smaller than wavelength or \hbar . Therefore \hbar gives quantum oscillatory detail to regular wavefunctions but plays the completely different role of a quantum smoothing parameter in irregular wavefunctions.

The regular and irregular behaviour described here should be obvious on computer-generated contour maps of eigenfunctions, provided these are 'semiclassical' enough. For a system with two degrees of freedom this would probably require eigenfunctions with about a hundred extrema (ten nodes in each direction), whose computation using suitable basis functions would involve diagonalising 200×200 matrices and is feasible with current technology.

For a quasi-integrable system the semiclassical limit will be more complicated than I have described here, because there will be some states not clearly identifiable as regular or irregular, associated with stochastic regions of small measure resulting from the destruction of tori whose frequency ratios are high-order rational numbers. A description of the different regimes expected as \hbar gets smaller is given by Berry (1977a, 1978).

Acknowledgments

The arguments presented here were put into their final form as a result of discussions

with Dr A Voros, and I would like to express my gratitude to him. I also thank Dr M Tabor for many conversations on this subject.

References

- Arnol'd V I 1963 *Usp. Mat. Nauk* **18** No. 5 13–39, No. 6 91–196 (1963 *Russ. Math. Surv.* **18** No. 5 9–36, No. 6 85–191)
- 1975 *Usp. Mat. Nauk* **30** No. 5 3–65 (1975 *Russ. Math. Surv.* **30** No. 5 1–75)
- Arnol'd V I and Avez A 1968 *Ergodic Problems of Classical Mechanics* (New York: Benjamin)
- Berry M V 1976 *Adv. Phys.* **25** 1–26
- 1977a *Phil. Trans. R. Soc. A* **287** 237–71
- 1977b *J. Phys. A: Math. Gen.* **10** 2061–81
- 1978 *Integrable and Stochastic Systems: a Primer* ed. R Helleman to be published
- Dvorin M M and Lazutkin V F 1973 *Funkt. Anal. Ego Pril.* **7** No. 2 20–7 (1974 *Funct. Anal. Applic.* 103–9)
- Einstein A 1917 *Verh. Dt. Phys. Ges.* **19** 82–92
- Ford J 1975 *Fundamental Problems in Statistical Mechanics* ed. E G D Cohen, vol. 3 (Amsterdam: North-Holland) pp 215–55
- Gutzwiller M C 1971 *J. Math. Phys.* **12** 343–58
- Jakeman E and Pusey P N 1975 *J. Phys. A: Math. Gen.* **8** 369–91
- Jakeman E, Pike E R and Pusey P N 1976 *Nature* **263** 315–7
- Kolmogoroff A N 1954 *Dokl. Akad. Nauk* **98** 527–30
- Lazutkin V F 1973 *Izv. Akad. Nauk, Mat. Ser.* **37** 186–216, 437–64 (1973 *Math. USSR Izv.* **7** 185–214, 439–66)
- Longuet-Higgins M S 1956 *Phil. Trans. R. Soc. A* **249** 321–87
- Moser J 1962 *Nachr. Akad. Wiss. Göttingen* **1** 1–20
- Percival I C 1973 *J. Phys. B: Atom. Molec. Phys.* **6** L229–32
- 1977 *Adv. Chem. Phys.* **36** 1–61
- Rice S O 1944 *Bell Syst. Tech. J.* **23** 282–332
- 1945 *Bell Syst. Tech. J.* **24** 46–156
- Thom R 1972 *Stabilité Structurelle et Morphogenèse* (Reading, Mass.: Benjamin) (English translation 1975)
- Voros A 1976 *Ann. Inst. Henri Poincaré A* **24** 31–90
- 1977 *Ann. Inst. Henri Poincaré A* **26** 343–403
- Whiteman K J 1977 *Rep. Prog. Phys.* **40** 1033–69